

Turned Pin D-Sub Connectors Solder Bucket

Solder cup

Machined contacts / Suitable for cable AWG 18
Tinned Shell as Standard
Class 2 connector pins as Standard
Other Plating and/or class on request.



Technical Data

Material Specification

Insulator: Self extinguishing TP, UL94 V-0
Shell: Steel, Tin Plated, Plug with dimples
Contacts: Copper Alloy
Contact: Hard Gold plated over Nickel
Quality Class: Class 2 (standard)

Electrical Specification

Test Voltage: 1000 V
Working Voltage: 125 V
Current Rating: 5 Amp
Contact Resistance: Max: 10mΩ before strain
ΔR max. 10mΩ after strain
DIN 41652, part 2 (MIL-C-24308)
Insulation Resistance: < 5GΩ
Clearance & Creepage: Contact - contact > 1.0mm
Contact - ground > 1.0mm
Operating Temp: -55°C to +125°C
Quality Classes: 1 - 500 mating cycles (0.8μ Au)
2 - 200 mating cycles (0.2μ Au)
S - 200 mating cycles (selective Au)

Plug connector

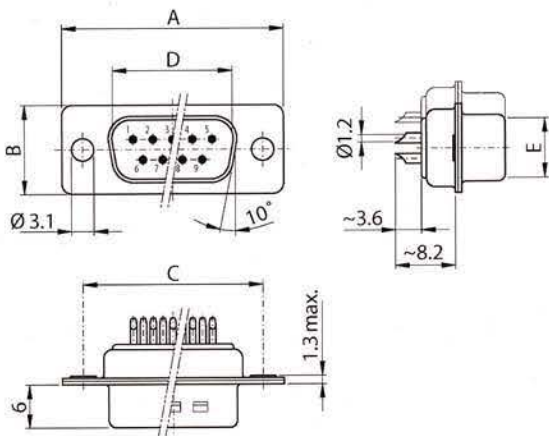

Size	A	B	C	D	E
09	30.80	12.40	25.00	16.79	08.23
15	39.20	12.40	33.30	25.12	08.23
25	53.10	12.40	47.00	38.84	08.23
37	69.50	12.40	63.50	55.30	08.23
50	67.00	15.40	61.10	52.68	10.95

Socket connector

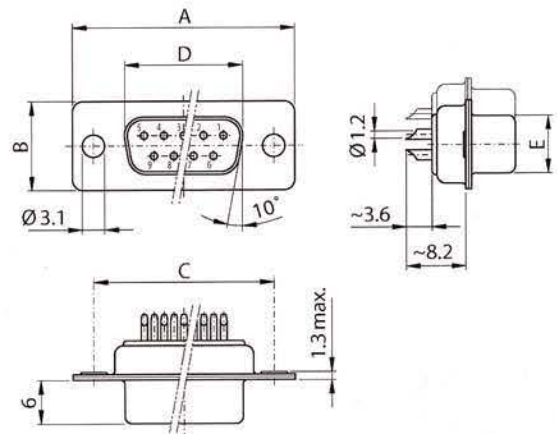

Size	A	B	C	D	E
09	30.80	12.40	25.00	16.46	08.02
15	39.20	12.40	33.30	24.79	08.02
25	53.10	12.40	47.00	38.50	08.02
37	69.50	12.40	63.50	54.96	08.02
50	67.00	15.40	61.10	52.55	10.87